

THE
COMPREHENSIVE
CATALOGUE
1987/8

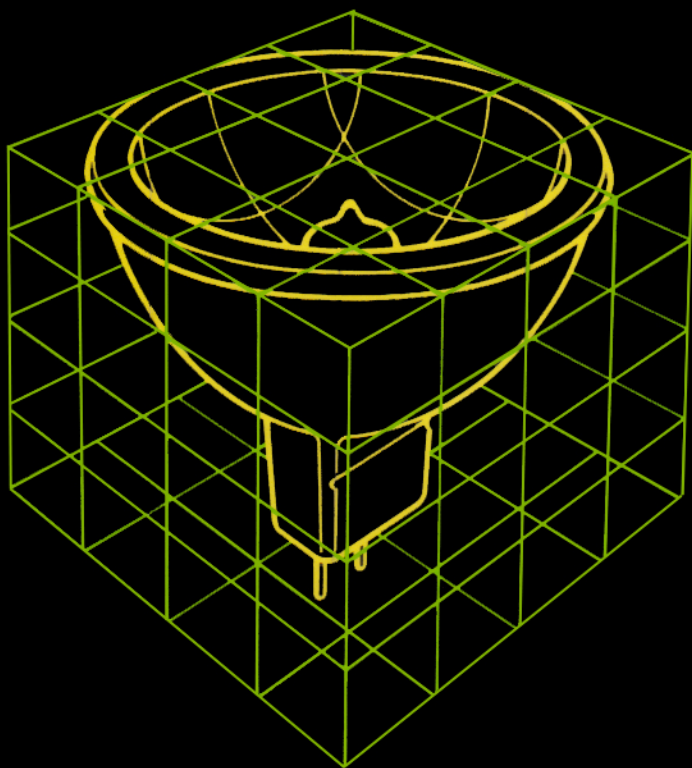

 **THORN EMI Lighting**

General Lamp Information	264
General Lighting Service Lamps	265
Decorative lamps	267
Special Service Lamps	268
Reflector Lamps	270
Sealed beam/low volt display lamps	271
Tubular lamps	272
Linear and tubular tungsten halogen lamps	273
Single ended dichroic halogen display lamps	274
Single ended tungsten halogen lamps	275
Tungsten halogen lampholders	276

GENERAL LAMP INFORMATION

INTRODUCTION

THORN EMI offer a comprehensive range of incandescent lamps suitable for domestic, commercial or industrial applications. Over 99% of the lamps listed in this section are manufactured in our UK factories where meticulous attention is paid to quality control and where the latest high speed manufacturing equipment ensures that a safe and reliable product is produced.

BRITISH AND INTERNATIONAL STANDARDS

Lamps described in this section comply with the following British and European standards where applicable:

British Standard	International Equivalent	Description
BS 161	IEC 64	Specification for tungsten filament lamps for general lighting service.
BS 5971	IEC 432	Safety and interchangeability of tungsten filament lamps for domestic and general lighting purposes.
BS 5101	—	Specification for lamp caps and holders together with gauges for the control of interchangeability and safety.
BS 6179	—	Specification for tungsten filament lamps for general lighting service with lives of 2000 hours.

DIMENSIONS

The dimensions shown in this section are in millimetres and, unless otherwise stated, are maximum values.

LAMP CAP CODE (for pictorial guide see page 281)

BS/IEC designation	Common designation	Description
B15d	SBC	Small bayonet cap
B22d	BC	Bayonet cap
B22d-3	3-pin BC	Bayonet cap—3 pin
BA20d	—	Bosch
E12	CAND	Candelabra screw
E14	SES	Small Edison screw
E27	ES	Edison screw
E40	GES	Goliath Edison screw

Note: The first number group in the IEC designation represents the diameter of the cap barrel in millimetres.

LUMEN OUTPUTS OF GLS LAMPS

This information is given in the table below. The figures are derived from National and International specifications and are provided for the guidance of lighting engineers. Initial lumens are the average lumen outputs at the start of life, while Lighting Design lumens are the average lumen outputs throughout the life of the lamp.

Watts	240V Initial lumens		Doublelife 240V Initial lumens		Netabulb 240V Initial lumens		110V Initial lumens		50V Initial lumens		25V Initial lumens	
	LDL*	LDL*	LDL*	LDL*	LDL*	LDL*	LDL*	LDL*	LDL*	LDL*	LDL*	LDL*
15W	115	105	—	—	—	—	—	—	—	—	—	—
25W	215	200	—	—	—	—	—	—	290	275	335	310
40W	410	390	370	350	385	365	500	460	495	465	620	580
60W	700	665	630	595	660	625	840	770	870	820	998	940
75W	940	890	—	—	—	—	—	—	—	—	—	—
100W	1330	1260	1200	1140	1250	1185	1580	1450	1600	1500	1720	1610
150W	2140	2030	1900	1800	2030	1925	2360	2160	—	—	—	—
200W	2880	2730	—	—	—	—	3250	2980	—	—	—	—
300W	4550	4300	—	—	—	—	5050	4710	5400	5050	—	—
500W	8200	7700	—	—	—	—	8900	8270	—	—	—	—
750W	13100	12400	—	—	—	—	—	—	—	—	—	—
1000W	18400	17300	—	—	—	—	—	—	—	—	—	—

* Lighting design lumens

AVERAGE LIFE AND INITIAL LUMENS

The quality control of GLS lamps has been extremely well developed, but because minute variations within laid down production tolerances produce proportionally greater changes in average life and lumens, it is impossible to guarantee these figures for an *individual* lamp.

The average life (the rated life of a doublelife lamp is 2000 hours; all others 1000 hours) and lumens quoted in our literature and on lamp cartons is calculated statistically by regularly measuring and life testing sample quantities of lamps to BS 161 and IEC 64, and taking these results as being representative of our production of a particular type of lamp. These results are recorded and over a period of time an on-going indication of quality is established. The average life of a small quantity of lamps should not be taken as typical unless the results are read in conjunction with BS 161 and IEC 64.

Operating conditions, particularly supply voltage and burning position, will affect achieved life. As can be seen from the following graph, a 5% increase in supply voltage will reduce the expected life by 50%, hence correct matching of lamp and supply voltage is essential.

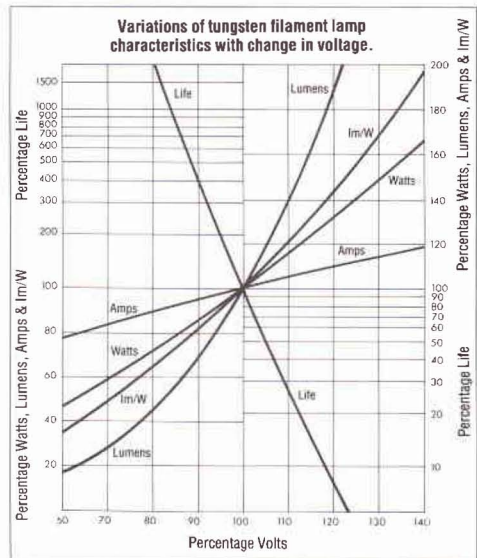

GENERAL LIGHTING SERVICE LAMPS

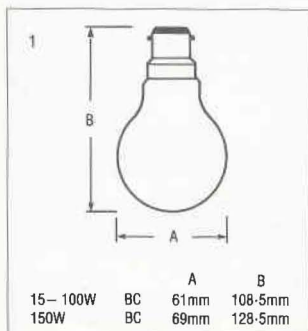

STANDARD GLS

Voltage	Watts	Cap	Finish	Diagram	Box Quantity*
240	40	BC	Pearl	1	ABC
240	60	BC	Pearl	1	ABC
240	100	BC	Pearl	1	ABC
240	150	BC	Pearl	1	AC

DOUBLE LIFE

Voltage	Watts	Cap	Finish	Diagram	Standard Pack*
240	40	BC	Pearl	1	D
240	60	BC	Pearl	1	D
240	100	BC	Pearl	1	D
240	150	BC	Pearl	1	D



COLOURED

Voltages	Watts	Cap	Finish	Diagram	Standard Pack*
200/250	15	BC	Amber, Blue, Green, Pink, Yellow, Red	1	D
200/250	25	BC	Amber, Blue, Green, Pink, Yellow, Red	1	D
200/250†	40	BC	Amber, Blue, Green, Pink, Yellow, Red	1	D
200/250†	60	BC	Amber, Blue, Green, Pink, Yellow, Red	1	D

†Not suitable for outdoor use unless enclosed for protection against rain.

NETABUL (MUSHROOM LAMP)

Voltage	Watts	Cap	Finish	Diagram	Standard Pack*
240	40	BC	Silverlight	2	A
240	60	BC	Silverlight	2	A
240	100	BC	Silverlight	2	A
240	150	BC	Silverlight	2	A

*BOX QUANTITIES

- A. 25 lamps in tuckend cartons.
- B. 100 lamps in Twinpacks, 50 Twinpacks per case.
- C. 100 lamps in tuckend cartons, shrink wrapped in 10's.
- D. 50 lamps in tuckend cartons, shrink wrapped in 10's.

GENERAL LIGHTING SERVICE LAMPS

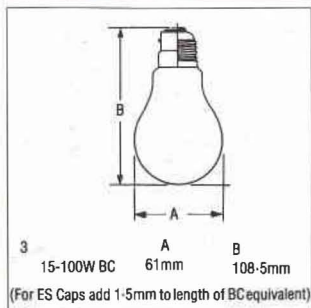

G.L.S. LAMP / NIGHT LIGHT

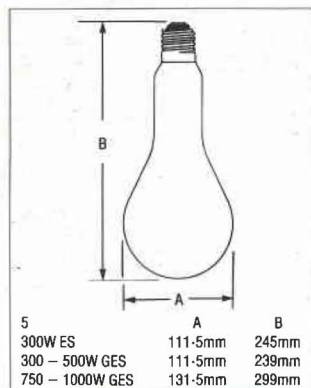

OTHER G.L.S. LAMPS

Voltage	Watts	Cap	Finish	Diagram	Standard Pack
110 VOLT					
110	40	BC	Pearl	3	25
110	60	BC	Clear	3	25
110	60	BC, ES	Pearl	3	25
110	100	BC	Clear	3	25
110	100	BC, ES	Pearl	3	25
110	150	BC, ES	Pearl	4	25
110	200	ES	Pearl	4	25
110	300	GES	Clear	5	10
110	300	ES	Clear	5	10
110	500	GES	Clear	5	10

240 VOLT

240	15	BC	Pearl	3	25
240	25	BC, ES	Pearl	3	25
240	40	ES	Pearl	3	25
240	40	BC	Clear	3	25
240	60	ES	Pearl	3	25
240	60	BC, ES	Clear	3	25
240	75	BC	Pearl	3	25
240	100	BC, ES	Clear	3	25
240	100	ES	Pearl	3	25
240	150	BC, ES	Clear	4	25
240	150	ES	Pearl	4	25
240	200	BC, ES	Clear	4	25
240	200	BC, ES	Pearl	4	25
240	300	ES, GES	Clear	5	10
240	500	GES	Clear	5	10
240	750	GES	Clear	5	10
240	1000	GES	Clear	5	10

250 VOLT

250	25	BC	Pearl	3	25
250	40	BC	Pearl	3	25
250	60	BC	Pearl	3	25
250	100	BC	Clear	3	25
250	100	BC	Pearl	3	25
250	150	BC	Clear	4	25
250	150	BC	Pearl	4	25
250	300	GES	Clear	5	10
250	500	GES	Clear	5	10
250	750	GES	Clear	5	10
250	1000	GES	Clear	5	10

NIGHTLIGHT

200/250	8/12	BC	Pearl	3	10
---------	------	----	-------	---	----

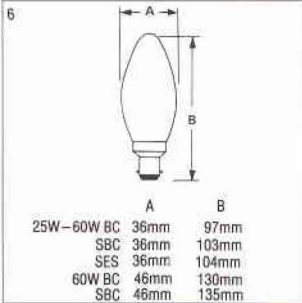

PLAIN CANDLE

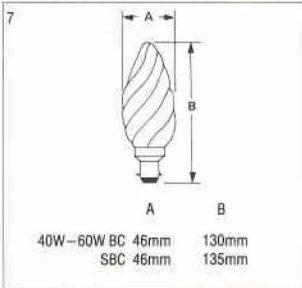

TWISTED CANDLE

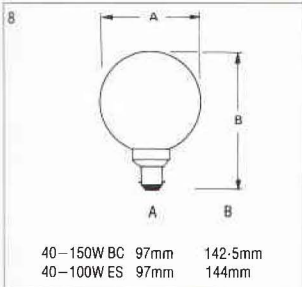

DECOR ROUND

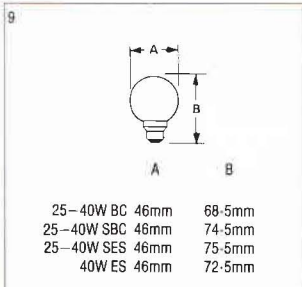

ROUND BULB

PLAIN CANDLE (36mm) VUPAK **

Voltage	Watts	Cap	Finish	Diagram	Standard Pack**
240	40	BC, SBC	Silverlight	6	50
240	40	BC, SBC	Clear	6	50
240	60	BC, SBC	Silverlight	6	50
240	60	BC, SBC	Clear	6	50

** Two candle lamps packed in a clear plastic bubble, sealed onto a backing card. 50 VUPAKS per outer box.

PLAIN CANDLE (36mm)

Voltage	Watts	Cap	Finish	Diagram	Standard Pack
240	25	BC, SBC	Clear	6	50*
240	25	BC, SBC, SES	Silverlight	6	50*
240	40	BC, SBC, SES	Clear	6	50*
240	40	BC, SBC, SES	Silverlight	6	50*
240	60	BC, SBC	Clear	6	50*
240	60	BC, SBC	Silverlight	6	50*

PLAIN CANDLE (46mm)

Voltage	Watts	Cap	Finish	Diagram	Standard Pack
240	60	BC, SBC	Clear	6	50*
240	60	BC, SBC,	Silverlight	6	50*
240	60	BC, SBC	Pearl	6	50*

TWISTED CANDLE (46 mm)

Voltage	Watts	Cap	Finish	Diagram	Standard Pack
240	40	BC, SBC	Clear	7	50*
240	40	BC, SBC	Pearl	7	50*
240	60	BC, SBC	Clear	7	50*
240	60	BC, SBC	Pearl	7	50*

DECOR ROUND (95mm)

Voltage	Watts	Cap	Finish	Diagram	Standard Pack
240	40	BC, ES	Clear	8	10
240	40	BC, ES	Silverlight	8	10
240	40	BC	Amber, Red, Green, Purple	8	10
240	60	BC, ES	Silverlight	8	10
240	100	BC, ES	Silverlight	8	10
240	150	BC	Silverlight	8	10

ROUND BULB (45 mm)

Voltage	Watts	Cap	Finish	Diagram	Standard Pack
240	25	BC, SBC, SES	Silverlight	9	50*
240	40	BC, SBC, ES, SES	Silverlight	9	50*

* Standard pack consists of 5 x 10-way packs per container.

SPECIAL SERVICE LAMPS

10

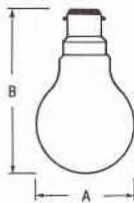

	A	B
60W BC	61	108.5
60W 3-PIN BC	61	108.5

FIREGLOW

FIREGLOW, VUPAK†

Voltage	Watts	Cap	Finish	Diagram	Standard Pack†
200/250	60	BC	Lacquered	10	50

† Single Fireglow lamp packed in a clear plastic bubble, sealed onto backing card.

FIREGLOW

Voltage	Watts	Cap	Finish	Diagram	Standard Pack
200/250	60	BC, 3-Pin BC	Lacquered	10	50

PIGMY SIGN

Voltage	Watts	Cap	Finish	Diagram	Standard Pack
25	15	BC, SBC	Clear	11	50
50	15	BC, SBC	Clear	11	50
110/120	15	BC, SBC, SES	Clear	11	50
200/250	15	BC, SBC, SES	Clear	11	50
200/250	15	BC, SBC	Amber, Blue, Green, Pink, Red, Yellow	11	50
200/250	25	BC, SBC, SES	Clear	11	50

PIGMY SIGN – ROUGH SERVICE

Voltage	Watts	Cap	Finish	Diagram	Standard Pack
200/250	15	BC, SBC, SES	Clear	11	50
200/250	25	BC, SBC, SES	Clear	11	50

PIGMY SIGN VUPAK*

Voltage	Watts	Cap	Finish	Diagram	Standard Pack
200/250	15	BC, SBC, SES		11	50
200/250	25	SBC		11	50

* Single Pigmy lamps, packed in a clear plastic bubble, sealed onto a backing card.

SWITCHBOARD INDICATOR

Voltage	Watts	Cap	Finish	Diagram	Standard Pack
200/260	8/12	BC	Clear	11	50

PILOT INDICATOR*

Voltage	Watts	Cap	Finish	Diagram	Standard Pack
50	10	SBC, CAND	Clear	12	25
100/130	10	SBC, SES, CAND	Clear	12	25
200/250	10	SBC, SES, CAND	Clear	12	25

* SES versions are intended for use in appliances only and not for general lighting.

11

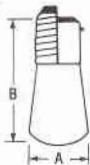

	A	B
15-25W BC	29	59
15-25WSBC	29	65
15-25W SES	29	66

PIGMY AND SWITCHBOARD INDICATOR

12

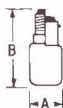

	A	B
10W SBC	19	43
10W CAND	19	48
10W SES	19	49

PILOT INDICATOR

SPECIAL SERVICE LAMPS

13

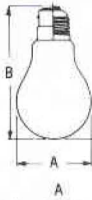

	A	B
40-60W	61mm	108.5mm
110/120V 100W	61mm	108.5mm
200/250V 100W	69mm	128.5mm

ROUGH SERVICE

ROUGH SERVICE

Voltage	Watts	Cap	Finish	Diagram	Standard pack
110/120	40	BC, ES	Pearl	13	25
110/120	60	BC, ES	Pearl	13	25
110/120	100	BC, ES	Pearl	13	25
200/250	40	BC, ES	Pearl	13	25
200/250	40	BC	Clear	13	25
200/250	60	BC, ES	Pearl	13	25
200/250	60	BC	Clear	13	25
200/250	100	BC, ES	Pearl	13	25
200/250	100	BC	Clear	13	25

14a

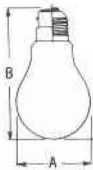

14b

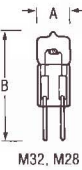

	A	B		A	B
65W ES	61mm	110mm	M32	8.5mm	44mm
			M28	11mm	45mm

TRAFFIC SIGNAL

TRAFFIC SIGNAL

Voltage	Watts	Nominal L.C.L.*	Cap	Finish	Diagram	Standard pack
240/250	65	62	ES	Clear	14a	25

* Light centre length

TUNGSTEN HALOGEN

12	50	M32	30	Bi-pin G6-35	Clear	14b	100
12	100	M28	30	Bi-pin G6-35	Clear	14b	100

15

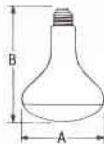

	A	B
150-275W	127.5mm	182.5mm

INFRA-RED REFLECTOR

HEATING LAMPS

INFRA-RED REFLECTOR Standard bulb (NOT for domestic use)

Voltage	Watts	Cap	Finish	Diagram	Standard pack
200/250	150	ES	Satin	15	10
200/250	275	BC	Satin	15	10
200/250	275	ES	Satin	15	10
200/250	275	BC, ES	Clear	15	10

INFRA-RED REFLECTOR Hard glass bulb (Domestic and other uses)

Voltage	Watts	Cap	Finish	Diagram	Standard pack
200/250	275	BC, ES	Clear front	15	10
200/250	275	BC, ES	Red front	15	10

REFLECTOR LAMPS

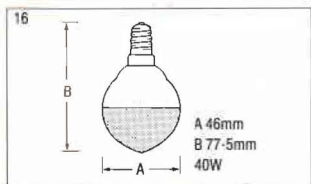

LS 45 LEMON SHAPE

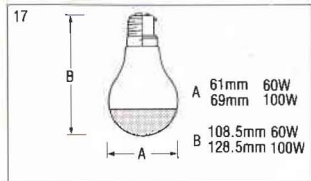

CROWN SILVERED



DECORSPT 50



DECORSPT 63

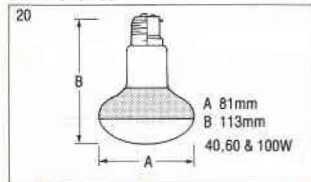

DECORSPT 80

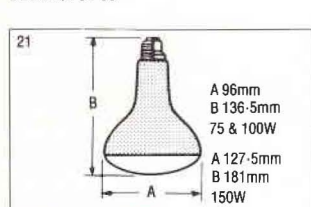

DECORSPT 95/125

(For ES caps add 1.5mm to length of BC equivalent)

LS 45 LEMON SHAPE

Voltage	Watts	Cap	Finish	Diagram	Standard pack
240	40	SES	Crown silvered	16	20

CROWN SILVERED DISPLAY

Voltage	Watts	Cap	Finish	Diagram	Standard pack
240	60	BC, ES	Crown silvered	17	25
240	100	3PBC, ES	Crown silvered	17	25

DECORSPT 50

Voltage	Watts	Cap	Finish	Diagram	Standard pack
240	25	SES	Light diffuse front	18	50
240	40	SES	Light diffuse front	18	50

DECORSPT 63

Voltage	Watts	Cap	Finish	Diagram	Standard pack
240	40, 60	ES	Light diffuse front	19	50
240	40, 60	ES	Clear front	19	50
240	60	BC	Light diffuse front	19	50
240	60**	ES	Disco lamp, Clear front, Lacquered Amber, Blue, Green, Red and Yellow	19	50

DECORSPT 80

Voltage	Watts	Cap	Finish	Diagram	Standard pack
240	40	BC, ES	Satin etch	20	10
240	60	BC, ES	Satin etch	20	10
240	60	BC, ES	Clear front	20	10
240	100	BC, ES	Satin etch	20	10
240	60**	ES	Disco lamp, Clear front, Lacquered Amber, Blue, Green, Red and Yellow	20	10

** This lamp is designed for non-continuous burning. If run continuously, lacquer could deteriorate after 500 hours.

DECORSPT 95

Voltage	Watts	Cap	Finish	Diagram	Standard pack
240/250	75	BC, ES	Light diffuse front	21	10
240/250	100	BC, ES	Light diffuse front	21	10
240/250	75	ES	Light diffuse front, Lacquered Amber, Blue, Green, Red and Yellow	21	10
240/250	100	ES	Light diffuse front, Lacquered Amber, Blue, Green, Red and Yellow	21	10

DECORSPT 125

Voltage	Watts	Cap	Finish	Diagram	Standard pack
240/250	150	BC, ES	Light diffuse front	21	10

SEALED BEAM LAMPS/LOW VOLT DISPLAY LAMPS

PAR SEALED BEAM SPOTLIGHTS AND FLOODLIGHTS

PAR 38 lamps are suitable for both indoor and outdoor applications. PAR 56 lamps should only be used indoors.

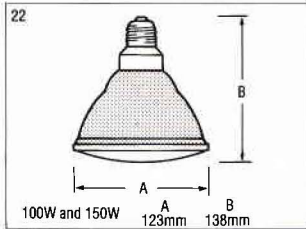

PAR 38

PAR 38 SEALED BEAM

Voltage	Watts	Cap	Finish	Diagram	Standard pack
240	100	ES	Clear front, Spot	22	12
240	100	ES	Clear front, Flood	22	12
240	100	ES	Flood lacquered Blue, Green, Red, Yellow, Amber	22	12
240	150	ES	Clear front, Spot	22	10
240	150	ES	Clear front, Flood	22	10

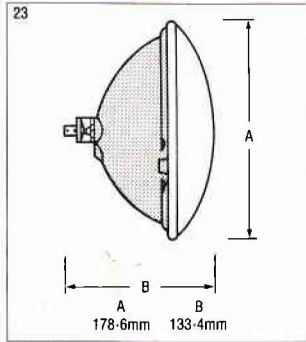

PAR 56

PAR 56 SEALED BEAM

Voltage	Watts	Cap	Finish	Diagram	Standard pack
240/250	300	GX16d	Clear front, Wide beam	23	6
240/250	300	GX16d	Clear front, Medium beam	23	6
240/250	300	GX16d	Clear front, Narrow beam	23	6

LOW VOLTAGE DISPLAY

Voltage	Watts	Cap	Finish	Ref	Diagram	Standard pack
12	24	SBC	Diffuse front	11-7005	24	25
12	50	Bosch	Crown silvered	11-7015	24	25
12	50	Bosch	Clear front	11-8012	24	25
12	50	ES	Clear front	11-7014	24	25

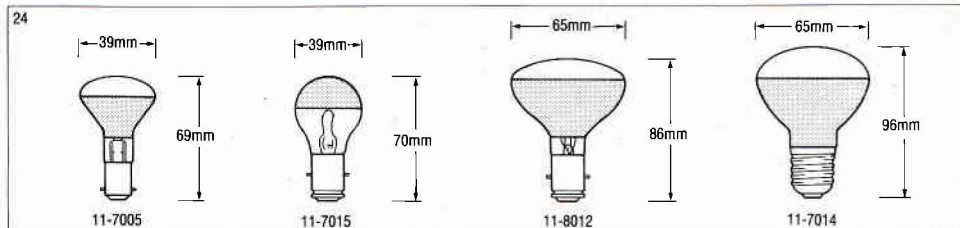

LOW VOLTAGE DISPLAY

TUBULAR LAMPS

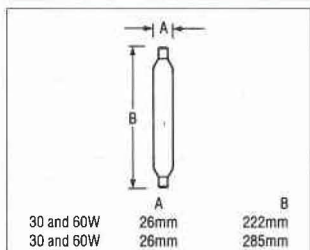

STRIPLIGHT

STRIPLIGHTS

Voltage	Watts	Length mm	Cap	Finish	Standard Pack
240	30	221	S15s	Clear	25
240	30	221	S15s	Opal	25
240	30	284	S15s	Clear	25
240	30	284	S15s	Opal	25
240	60	221	S15s	Clear	25
240	60	221	S15s	Opal	25
240	60	284	S15s	Clear	25
240	60	284	S15s	Opal	25

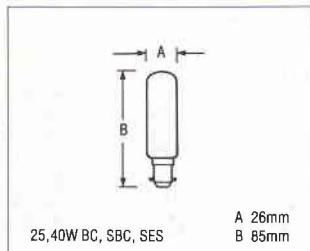

SINGLE CAP TUBULAR

SINGLE CAP TUBULAR

Voltage	Watts	Cap	Finish	Standard Pack
240	25	BC, SBC, SES	Clear	50
240	40	BC, SBC	Clear	50



VUPAKS—IDEAL FOR RETAIL OUTLETS

LINEAR AND TUBULAR TUNGSTEN HALOGEN LAMPS

OPERATING TEMPERATURES

During operation, the temperature of the lamp pinch seal should not exceed 350°C, whilst the bulb wall temperature must not drop below 250°C in order to maintain the tungsten halogen cycle.

FUSING

It is recommended that a suitably rated fuse be used in the luminaire or external circuit, as listed.

RECOMMENDED FUSE RATINGS (HBC type)

Lamp watts	110/120V	200/250V
100-300	3-15A	2A
500	6-3A	4A
750	10A	4A
1000	10A	6A
1500		10A
2000		10A

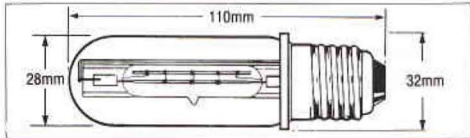
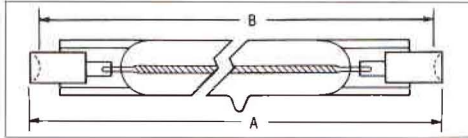

TUBULAR LAMPS

Lamp type	Voltage	Watts	Caps	Rated average life hrs	Nominal lumens*	Colour temp.*K	Operating position
K16	120	100	E27	4000	1450	2850	Universal
K16	200/230	100	E27	4000	1350	2850	Universal
K16	240/250	100	E27	4000	1350	2850	Universal
K13	120	150	E27	4000	2300	2850	Universal
K13	200/230	150	E27	4000	2100	2850	Universal
K13	240/250	150	E27	4000	2100	2850	Universal

LINEAR LAMPS

Lamp type	Voltage	Watts	Caps	Contact to ceramic max (A) mm	Contact to contact (B) mm	Rated average life hrs.	Nominal lumens*	Colour temp.*K	Operating position
K14	120	100	R7s	78-3	74.9 ± 1.6	4000	1450	2850	Universal
K14	200/230	100	R7s	78-3	74.9 ± 1.6	4000	1350	2850	Universal
K14	240/250	100	R7s	78-3	74.9 ± 1.6	4000	1350	2850	Universal
K12	120	150	R7s	78-3	74.9 ± 1.6	4000	2300	2850	Universal
K12	200/230	150	R7s	78-3	74.9 ± 1.6	4000	2100	2850	Universal
K12	240/250	150	R7s	78-3	74.9 ± 1.6	4000	2100	2850	Universal
K11	120	200	R7s	117-6	114.2 ± 1.6	4000	3200	2900	Universal
K11	200/230	200	R7s	117-6	114.2 ± 1.6	4000	3100	2900	Universal
K11	240/250	200	R7s	117-6	114.2 ± 1.6	4000	3100	2900	Universal
K15	120	250	R7s	78-3	74.9 ± 1.6	4000	4300	2900	Universal
K15	200/230	250	R7s	78-3	74.9 ± 1.6	4000	4000	2900	Universal
K15	240/250	250	R7s	78-3	74.9 ± 1.6	4000	4000	2900	Universal
K9	110/115	300	R7s	117-6	114.2 ± 1.6	4000	5250	2900	Universal
K9	200/230	300	R7s	117-6	114.2 ± 1.6	4000	5000	2900	Universal
K9**	240/250	300	R7s	117-6	114.2 ± 1.6	4000	5000	2900	Universal
K1	110	500	R7s	117-6	114.2 ± 1.6	2000	10500	2900	Horizontal
K1	120	500	R7s	117-6	114.2 ± 1.6	2000	10500	2900	Horizontal
K1	200/230	500	R7s	117-6	114.2 ± 1.6	2000	9500	2900	Horizontal
K1	240/250	500	R7s	117-6	114.2 ± 1.6	2000	9500	2900	Horizontal
K3	200/230	750	R7s	189-1	185.7 ± 1.6	2000	15000	3000	Horizontal
K3	240/250	750	R7s	189-1	185.7 ± 1.6	2000	15000	3000	Horizontal
K4	110	1000	R7s	189-1	185.7 ± 1.6	2000	22000	3000	Horizontal
K4	200/230	1000	R7s	189-1	185.7 ± 1.6	2000	21000	3000	Horizontal
K4	240/250	1000	R7s	189-1	185.7 ± 1.6	2000	21000	3000	Horizontal
K10	200/230	1000	R7s	254-1	250.7 ± 1.6	2000	21000	3000	Horizontal
K10	240/250	1000	R7s	254-1	250.7 ± 1.6	2000	21000	3000	Horizontal
K5	200/230	1500	R7s	254-1	250.7 ± 1.6	2000	33000	3000	Horizontal
K5	240/250	1500	R7s	254-1	250.7 ± 1.6	2000	33000	3000	Horizontal
K8	200/230	2000	R7s	331-0	327.4 ± 1.6	2000	44000	3000	Horizontal
K8	240/250	2000	R7s	331-0	327.4 ± 1.6	2000	44000	3000	Horizontal

* The lumen output of individual lamps will be subject to normal commercial tolerances.

** Also available frosted

SINGLE ENDED DICHOIC HALOGEN DISPLAY LAMPS (INCLUDING LIGHTSTREAM)

ADVANTAGES OF LOW VOLT HALOGEN DICHOIC LAMPS

1. Compactness
2. High efficacy
3. Good colour rendering
4. Long life
5. Universal burning position
6. Virtually 100% lumen maintenance
7. Robust construction
8. Low voltage safety
9. Cool beam

LAMP HOLDERS

Appropriate lampholders covering this range are on page 276.

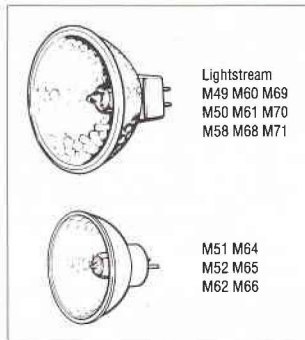
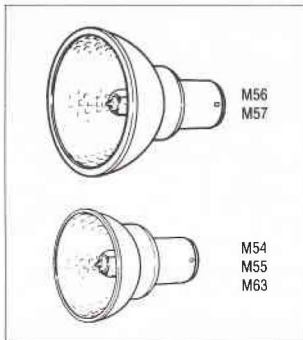

FUSING

It is recommended that a suitably rated fuse be used in the luminaire or external circuit.

TRANSFORMERS

A range of step-down transformers for single and multi lamp application is available. It is important that where applicable only THORN EMI transformers are used with these lamps. THORN EMI Lighting cannot accept any responsibility if transformers other than those shown on page 142 (which comply with the relevant international specifications) are used.

FRONT FILTERS

For 50mm dichroic reflectors a range of clip-on front glasses is available in clear, red, green, blue and yellow. For details see page 142.

OPERATING TEMPERATURES

During operation the temperatures of the lamp pinch seal should not exceed 350°C, while the bulb wall temperature must not drop below 250°C in order to maintain the tungsten-halogen cycle.

SINGLE ENDED HALOGEN DISPLAY LAMPS

Lamp ref.	Voltage	Watts	Cap	Maximum overall length mm	Maximum flange diameter mm	Nominal lumens or peak intensity cds	Beam angle to 1/2 peak°	Mirror type
M64	12	12	GZ4	35-0	35-3	6400	7	Dichroic, spot
M51	12	20	GZ4	35-0	35-3	1760	17	Dichroic, medium
M52	12	20	GZ4	35-0	35-3	5500	10	Dichroic, spot
M54	12	20	SBC	42-0	35-3	1760	17	Dichroic, medium
M55	12	20	SBC	42-0	35-3	5500	10	Dichroic, spot
M62	12	20	GZ4	35-0	35-3	600	30	Dichroic, flood
M63	12	20	SBC	42-0	35-3	600	30	Dichroic, flood
M68	12	20	GX5-3	44-5	50-7	5000	11	Dichroic, spot
M69	12	20	GX5-3	44-5	50-7	1000	24	Dichroic, medium
M65	12	35	GZ4	35-0	35-3	9000	8	Dichroic, spot
M66	12	35	GZ4	35-0	35-3	3000	20	Dichroic, medium
M71	12	35	GX5-3	44-5	50-7	3600	18	Dichroic, medium
M70	12	35	GX5-3	44-5	50-7	9000	8	Dichroic, spot
M49	12	50	GX5-3	44-5	50-7	12000	10	Dichroic, spot
M50	12	50	GX5-3	44-5	50-7	3700	21	Dichroic, medium
M56	12	50	SBC	50-0	50-7	3700	21	Dichroic, medium
M57	12	50	SBC	50-0	50-7	12000	10	Dichroic, spot
M58	12	50	GX5-3	44-5	50-7	1550	38	Dichroic, flood
M60	12	75	GX5-3	44-5	50-7	16000	12	Dichroic, spot
M61	12	75	GX5-3	44-5	50-7	2250	38	Dichroic, flood

Rated average life:
M64 2000 hours
all other lamps 3000 hours

Dichroic coated mirrors reduce by 50% the heat forward. Consequently higher temperatures can be generated behind the lamp than for comparable aluminised reflectors. For dimensional cross section diagrams of lamps with GX5.3 and GZ4 caps see page 141

SINGLE ENDED TUNGSTEN HALOGEN LAMPS

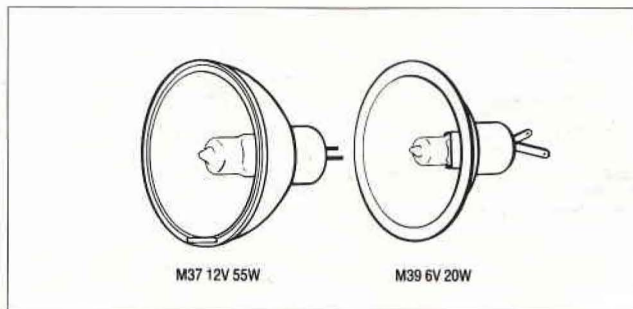
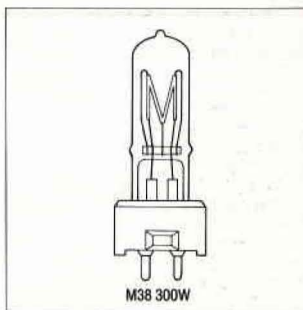
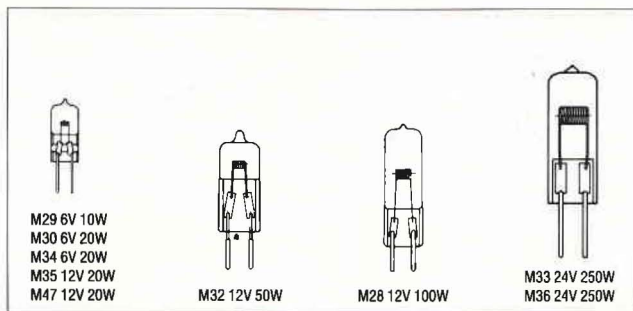

SINGLE ENDED TUNGSTEN HALOGEN LAMPS

Lamp type	Voltage	Watts	Base	Maximum overall length mm	Maximum bulb diameter mm	Nominal lumens	Rated average life hrs.	Operating position	
M29	6	10	G4	30-0	8-5	210	100	Universal	For film editors
M30	6	20	G4	30-0	8-5	420	100	Universal	For film editors
M34	12	20	G4	30-0	8-5	350	2000	Universal	
M39	6	20	2 Tab	39-0	50-0	—	—	—	Ellipsoidal mirror
M35*	12 (13-2)	20 (23)	G4	30-0	8-5	400 (500)	250 (100)	Universal	
M47	6	20	G4	30-0	8-5	350	2000	Universal	
M32	12	50	GY6-35	44-0	12-0	850	3000	Universal	
M37	12	55	GY6-35	42-0	50-0	—	—	—	Fibre optic display
M28	12	100	GY6-35	44-0	11-0	2400	2000	BD ± 90°	
M67	24	100	GY6-35	44-0	11-0	1800	2000	BD ± 90°	Base up only with heat sinks
M33	24	250	GY6-35	55-0	13-5	8400	300	BD ± 90°	
M36	24	250	GY6-35	58-0	15-0	5750	2000	BD ± 90°	
M38	240/250	300	GY9-5	80-0	30-0	5000	2000	Universal	
M40	240/250	500	GY9-5	85-0	30-0	8500	2000	Universal	

* M35 lamp can be operated at 13-2V

TUNGSTEN HALOGEN LAMPHOLDERS

GL 1079

The GL 1079 series are for use with miniature tungsten halogen LV lamps having G6-35 caps, e.g. M28, M32, M33, M36, M37 and M67. Both tab and lead wire versions are available. The basic flat holder is suitable where the lamp is not subject to any vibration and is unlikely to sag. Where extra support for the lamp is necessary the versions with springs which support the lamp pinch are recommended.

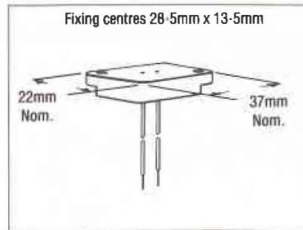

GL 1079-W



GL 1079-SLW

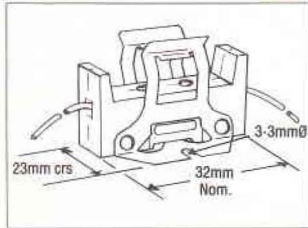

GL 1177

GL 1105 is superseded by GL 1177 (same mounting centres) suitable for GY9-5 caps e.g. A1/233, A1/247, and M38.

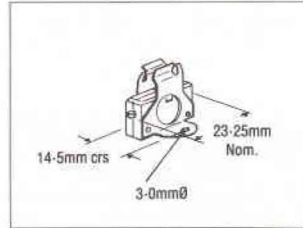

GL 1123-A

Suitable for use with low volt miniature tungsten lamps having G 4 caps. eg. M29, M30, M34, M35.

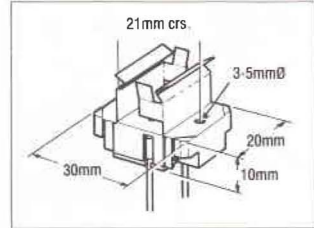

GL 1228

For use with Lightstream GX5-3 Base display lamps. Lamp requires no front mount.

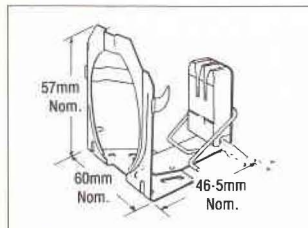

GL 1210

Lampholder for 50mm Lightstream lamps with GX5.3 base e.g. M49, M50, etc. Fixing centres 38mm x 3.3mmØ

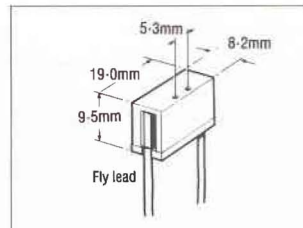

GL 1218

For lamps with GX5-3 Base eg. M49, M50.

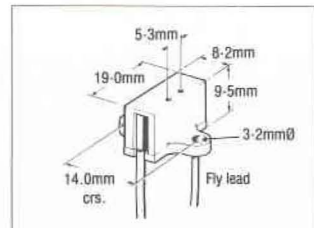

GL 1219

For lamps with GX5-3 Base e.g. M49, M50.

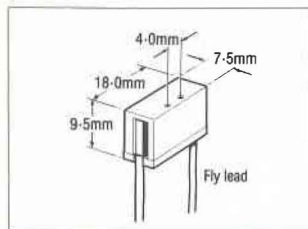

GL 1211

For lamps with G4/GZ4 Base e.g. M29, M35, M48 and M51.

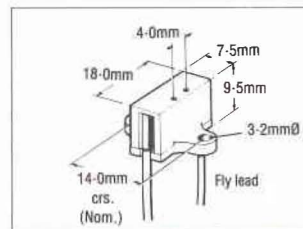

GL 1212

For lamps with G4/GZ4 Base e.g. M29, M35, M48 and M51.

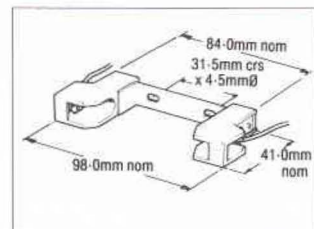

SUL 150

For use with 150W K12 TH lamp.